

ITEM NO.	PART NUMBER	DESCRIPTION	QTY.
1	K0075-A-002-OPENED	CC360-30TH SECTIONALIZING ENCLOSURE - PAINTED EQUIP. GREEN	1
2	K0024-P-016	WIND BRACKET	2
3	K0075-W-004	EQUIPMENT PANEL, ASA-61 GREY	1
4	95462A029	SS 1/4-20 NUT	6
5	92620A709	SS-1/4 Hex Head Screw	2
6	K0075-A-003	GROUND BAR WITH 92941A716-1/2-13 BRONZE BOLT, 92676A470-1/2-13 BRONZE NUT	1
7	61216202 SHOP	PENTA BOLT	2



151 INDUSTRIAL PARK RD., COLBORNE, ONTARIO
WWW.FRONTIERDISTRIBUTIONPRODUCTS.COM

D

D

C

C

B

B

A

A

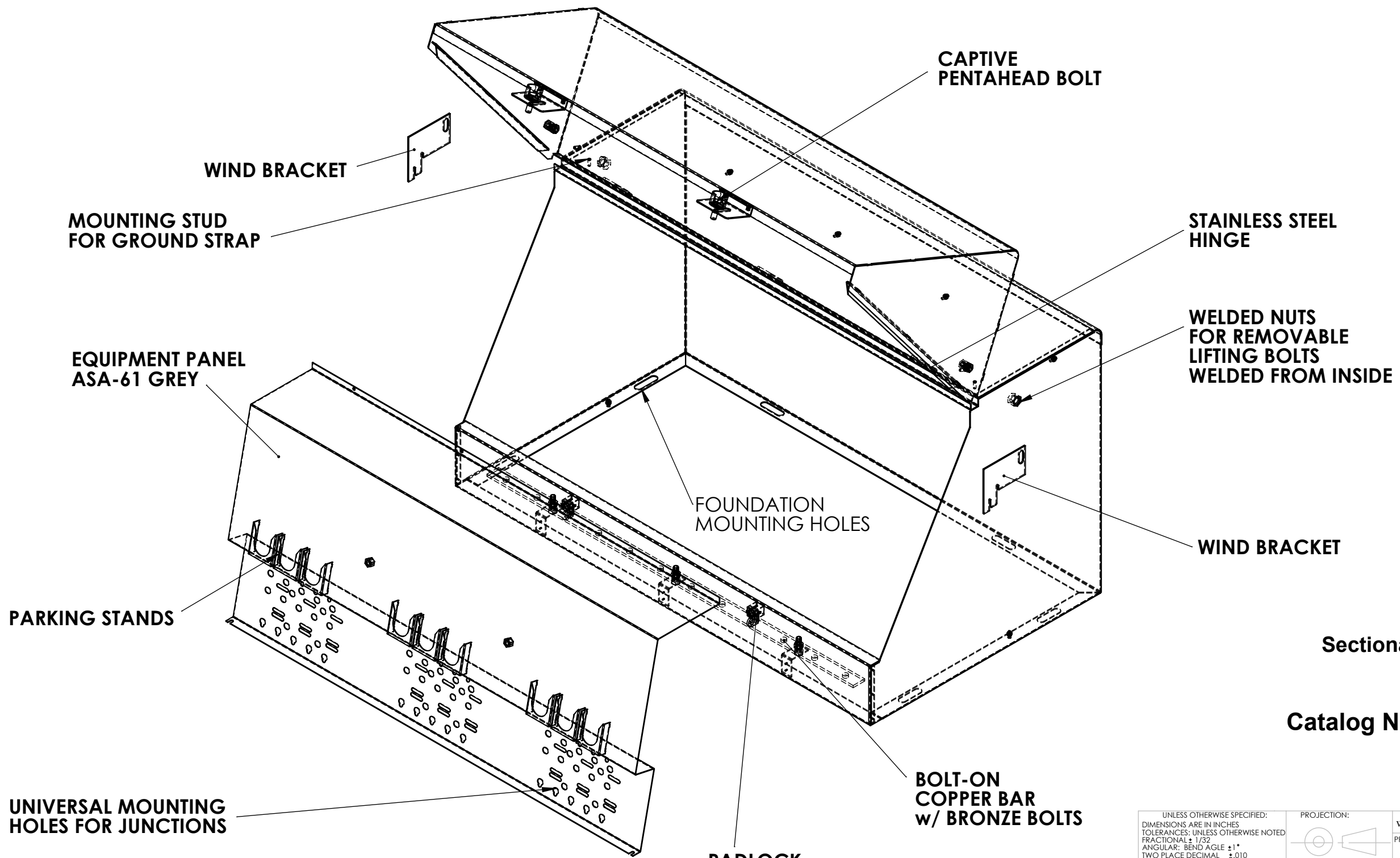

**Sectionalizing Enclosure, 3-Phase,
28kV (30"H x 54"W x 30"D)**

Catalog Number: 055CC354-30TH



UNLESS OTHERWISE SPECIFIED: DIMENSIONS ARE IN INCHES TOLERANCES: UNLESS OTHERWISE NOTED FRACTIONAL: ± 1/32 ANGULAR: BEND ANGLE ± 1° TWO PLACE DECIMAL ± .010 THREE PLACE DECIMAL ± .005		PROJECTION: 	www.FrontierDistributionProducts.com
MATERIAL 12GA MILD STEEL	FINISH PAINT TBD	TITLE 055CC354-30TH	SIZE 11 X 17
DRAWN	DATE 2025-04-28	DWG. NO. K0075-A-001	REV 1 SHEET 1 OF 2



2 LIFTING NUTS
WELDED FROM INSIDE

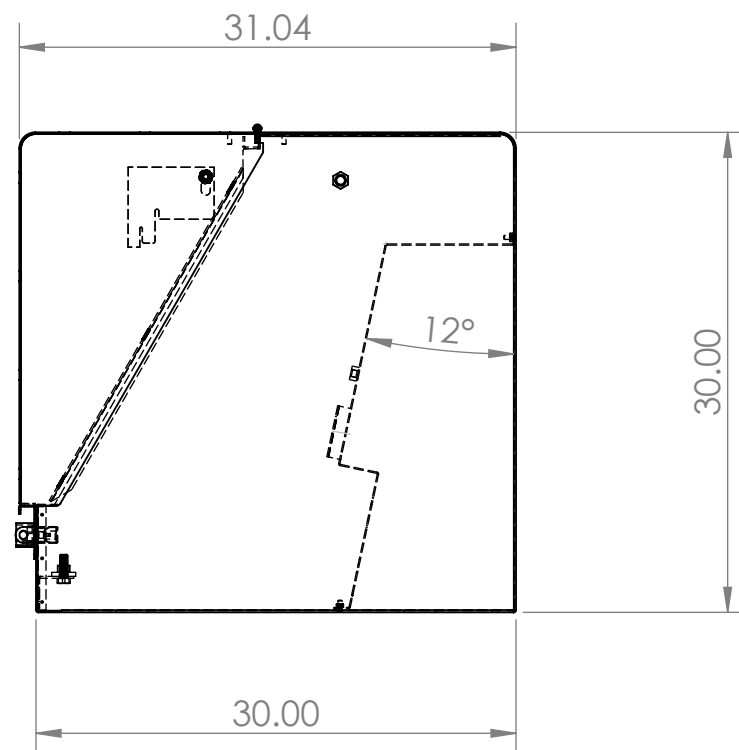
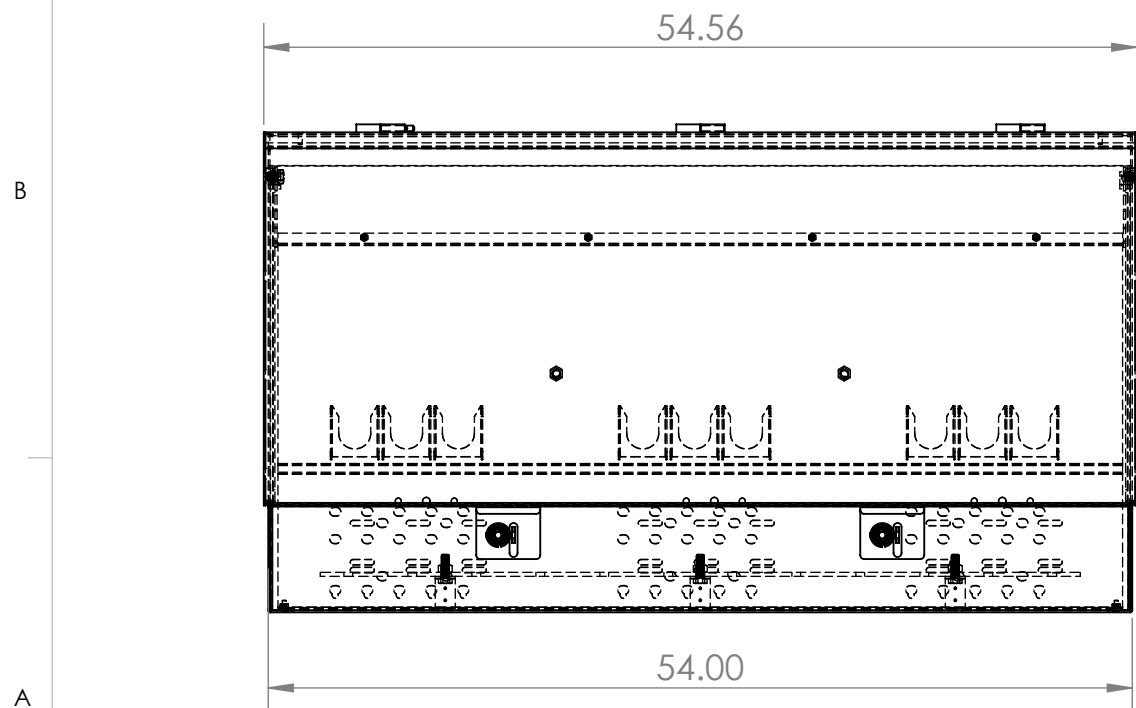
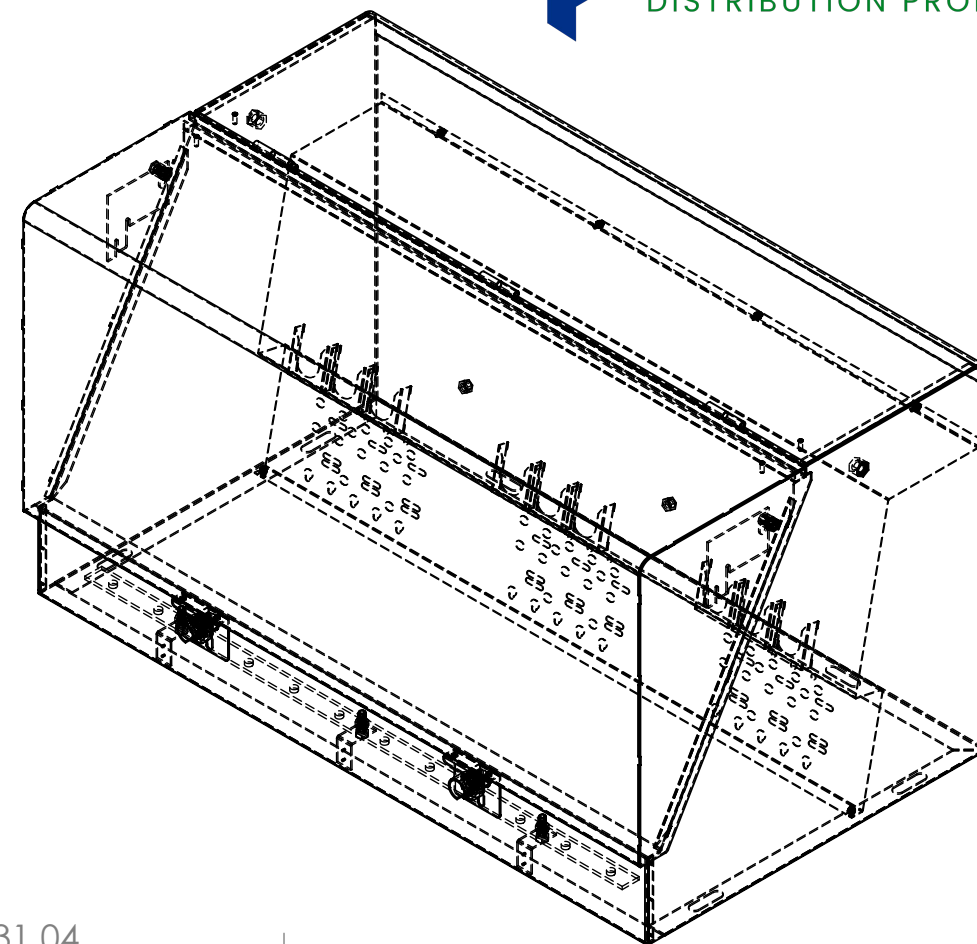
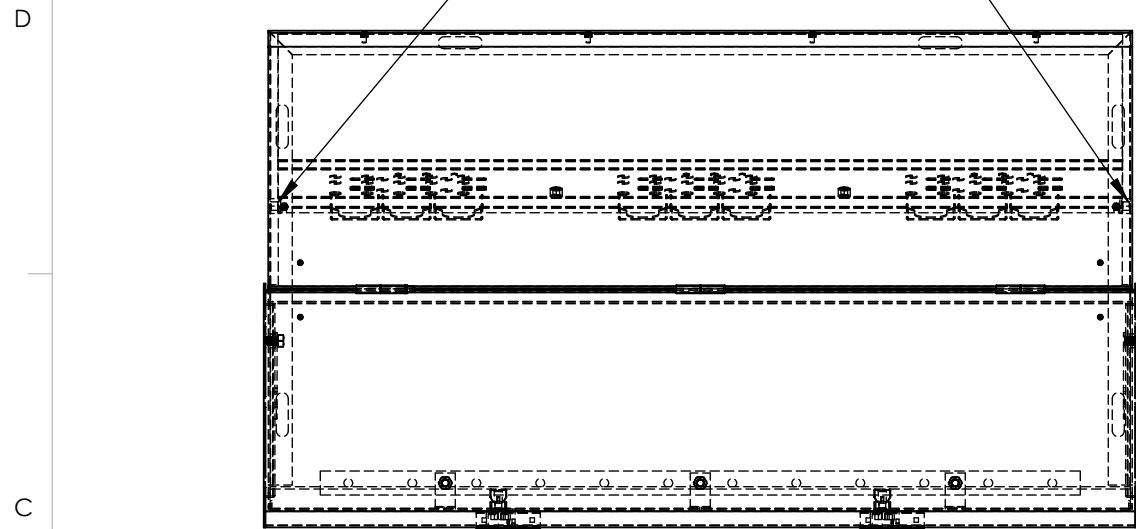

MADE IN CANADA

UNLESS OTHERWISE SPECIFIED: DIMENSIONS ARE IN INCHES TOLERANCES: UNLESS OTHERWISE NOTED FRACTIONAL ± 1/32 ANGULAR: BEND ANGLE ± 1° TWO PLACE DECIMAL ± .010 THREE PLACE DECIMAL ± .005		PROJECTION: 	www.FrontierDistributionProducts.com	
MATERIAL 12GA MILD STEEL		FINISH PAINT TBD	TITLE: 055CC354-30TH	SIZE 11 X 17
DRAWN	DATE 2025-04-28	DWG. NO. K0075-A-001	REV 1	SHEET 2 OF 2